

# X07

## Tiltrotator 5-7 tonnes

---



### A tiltrotator optimized for compact excavators between 5 and 7 tonnes

Steelwrist small tiltrotators are developed with a focus on flexibility, building height and low weight, that is so important for compact excavators. With a steel cast structure, the weight can be reduced, while strength is maximized.

#### Take on a variety of tasks with a tiltrotator on your compact excavator

Compact excavators are often used in different construction projects like landscaping, material handling, stump removal or light demolition. With the tiltrotator you increase the ability to reach tight spaces, and save time and reduce wear on both machine and surroundings as the need for machine movements at the worksite is minimized. The tiltrotator is exceptionally useful when digging trenches and for sewer lines in utility work, and in combination with a grapple you have a versatile setup for removing debris, or placing and removing trees.



A compact excavator with a tiltrotator is a good choice for construction work at busy and confined sites in the city, with workers and citizens on the move nearby. The tiltrotator brings more manoeuvrability in a sensitive area, while delivering excellent earthmoving capacities and efficiency for the excavator. A Direct Fit configuration is often chosen for compact excavators, where the tiltrotator is permanently mounted to the dipper arm.

Steelwrist quick couplers and tiltrotators follow the symmetrical standard (S-standard), the fastest growing coupler type internationally. The attachment coupler on the tiltrotator has Front Pin Hook (FPH) or Front Pin Lock (FPL), depending on coupler size, for safe work tool changes. The tiltrotator is delivered with a control system that fits your excavator regardless if you need a two or four hose solution.

#### Control system

Steelwrist supply two types of tiltrotator control systems. Quantum is an advanced control system where ergonomics, easy installation and fuel efficiency, remote support and automatic tool recognition are important parts of the system. The four hose proportional machine control is the more basic system.

#### Gripper cassette (option)

Equip the tiltrotator with a gripper cassette with a finger gripper that will make your excavator even more flexible, handling objects with precision. The gripper cassette can be retrofitted.

#### Central lubrication (option)

Our tiltrotators can be equipped directly from factory with central lubrication that fits all central lubrication systems on the market.

*The X07 tiltrotator is also available with Verachtert (CW) or Lehnhoff (HS) coupler interface. For Verachtert (CW) the tiltrotator always has a Direct fit configuration.*

## Teknisk specifikation

Machine Interface	S40	S45	S50	DF	DF	DF
Tiltrotator Quick Coupler	S40	S45	S50	S40	S45	S50
Machine weight [lb]	11000-15400	11000-15400	11000-15400	11000-15400	11000-15400	11000-15400
Max Breakout torque [kNm]	65	65	65	65	65	65
Weight from [lb]	330	330	330	330	330	330
Building height [inch]	14.57	14.57	14.57	15.75	15.75	15.75
Length [inch]	22.64	22.64	22.64	25	25	25
Cylinder width [inch]	16.42	16.42	16.42	22.60	22.60	22.60
Max tilt angle [degrees]	±45	±45	±45	±45	±45	±45
Max width dipper arm [inch]	-	-	-	9.45	9.45	9.45
Pin diameter [inch]	-	-	-	1.77-2.17	1.77-2.17	1.77-2.17
Pin distance [cc-measure] [inch]	-	-	-	8.66-12.20	8.66-12.20	8.66-12.20
Pin distance [cc-measure] [mm]	-	-	-	220-310	220-310	220-310
Tilt Torque [kNm]	13,8	13,8	13,8	13,8	13,8	13,8
Rotational Torque [kNm]	5,2	5,2	5,2	5,2	5,2	5,2
Hydraulic AUX with gripper	1	1	1	1	1	1
Hydraulic AUX without gripper	1	1	1	1	1	1
Lifting hook [lb]	-	-	-	4400	4400	4400
Oil Flow [gallons/min]	11	11	11	11	11	11
Max pressure [bar]	210	210	210	210	210	210
Max Pressure Separate AUX [bar]	350	350	350	350	350	350
Safety solution	FPH	FPL	FPL	FPH	FPL	FPL

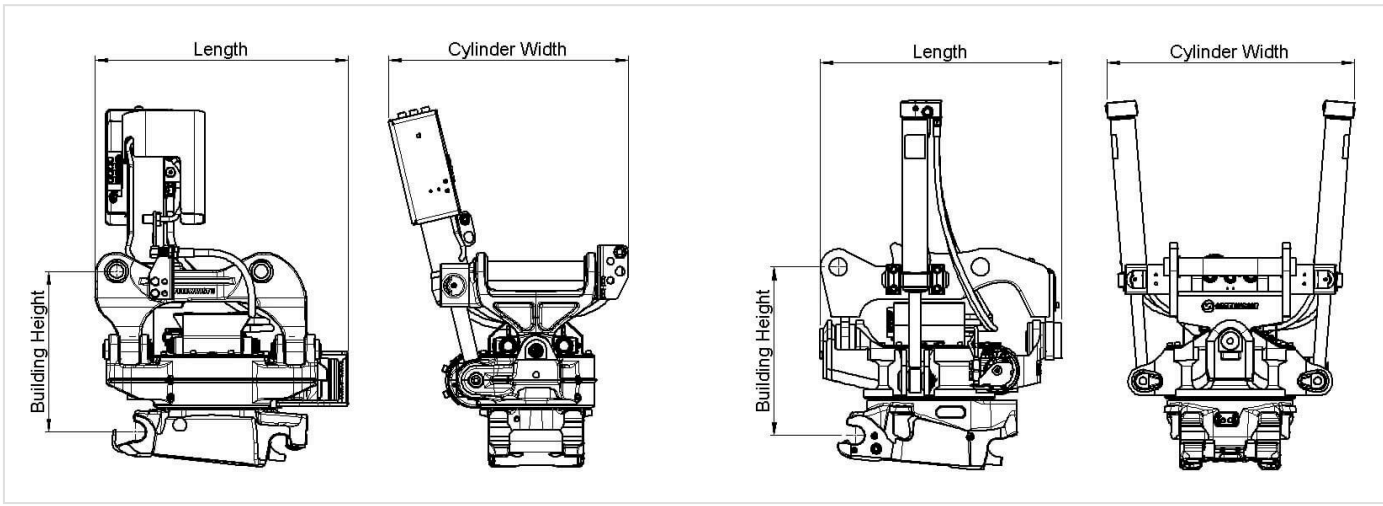

**S-Standard**

**Symmetrical Quick Couplers for Excavators (S-standard)**

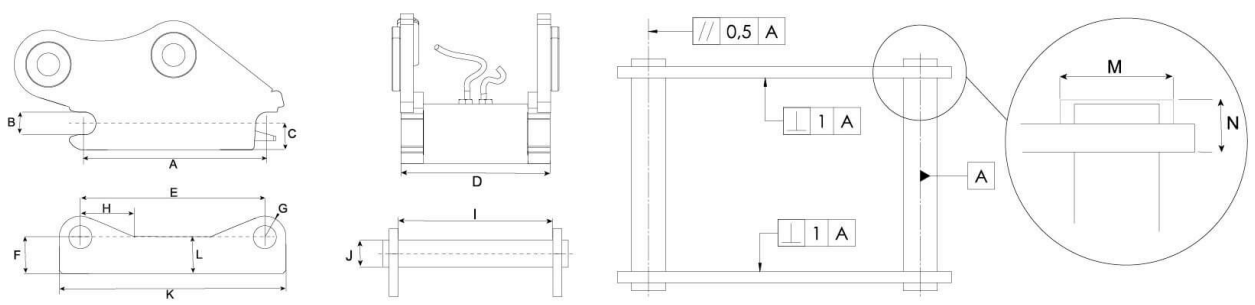

Dimensions and tolerance table

Measurements (mm)	S30 /150	S30 /180	S40	S40 /240	S45	S50	S60	S70	S80	S90 /620	S90 /750	S100	S120
A	199,8 ±0,2	229,8 ±0,2	299,8 ±0,2	299,8 ±0,2	429,8 ±0,2	429,8 ±0,2	479,8 ±0,2	599,8 ±0,2	669,8 ±0,2	749,8 ±0,2	749,8 ±0,2	899,8 ±0,2	924,8 ±0,2
B	30	30	40	40	45	50	60	70	80	90	90	100	120
C	Max 40	Max 45	Max 50	Max 50	Max 65	Max 85	Max 80	Max 100	Max 115	Max 125	Max 125	Max 150	Max 200
D	148 ±1	178 ±1	198 ±1	238 ±1	288 ±1	268 ±1	338 ±1	448 ±1	588 ±1	618 ±1	748 ±1	748 ±1	868 ±1
E	200,5 ±0,5	230,5 ±0,5	300,5 ±0,5	300,5 ±0,5	430,5 ±0,5	430,5 ±0,5	480,5 ±0,5	600,5 ±0,5	670,5 ±0,5	750,5 ±0,5	750,5 ±0,5	900,5 ±0,5	925,5 ±0,5
F	Min 45	Min 50	Min 55	Min 55	Min 70	Min 70	Min 85	Min 115	Min 135	Min 155	Min 155	Min 175	Min 240
G	Max 30	Max 30	Max 40	Max 40	Max 45	Max 45	Max 60	Max 75	Max 90	Max 110	Max 110	Max 125	Max 145
H	Max 85	Max 85	Max 100	Max 100	Max 125	Max 125	Max 150	Max 250	Max 250	Max 250	Max 250	Max 250	Max 250
I	152 ±1	182 ±1	202 ±1	242 ±1	292 ±1	272 ±1	342 ±1	452 ±1	592 ±1	622 ±1	752 ±1	752 ±1	872 ±1
J	30	30	40	40	45	50	60	70	80	90	90	100	120
K	Max 260	Max 290	Max 380	Max 380	Max 520	Max 520	Max 600	Max 740	Max 830	Max 1000	Max 1000	Max 1150	Max 1250
L	Max 45	Max 50	Max 55	Max 55	Max 70	Max 70	Max 85	Max 115	Max 135	Max 200	Max 200	Max 250	Max 300
M	Max 62	Max 62	Max 72	Max 72	Max 77	Max 77	Max 92	Max 102	Max 122	Max 132	Max 132	Max 142	Max 162
N	Max 25	Max 25	Max 28	Max 28	Max 30	Max 30	Max 35	Max 40	Max 55	Max 70	Max 70	Max 75	Max 80

Load table

Quick Coupler Size	Width (mm)	Shaft c-c (mm)	Shaft diameter (mm)	Minimum Positive Torque (kNm)	Minimum Negative Torque (kNm)	Max recommended machine weight (ton)
S30/150	150	200	30	28	20	2
S30/180	180	230	30	28	20	2
S40	200	300	40	35	23	6
S40/240	240	300	40	40	26	7
S45	290	430	45	65	42	11
S50	270	430	50	65	42	11
S60	340	480	60	150	75	18
S70	450	600	70	300	195	30
S80	590	670	80	600	390	40
S90/620	620	750	90	1000	650	70
S90/750	750	750	90	1000	650	70
S100	750	900	100	1200	775	85
S120	925	870	120	1600	1000	100